

DSL1120

RECESSED BRICK, STEP AND WALL LIGHT

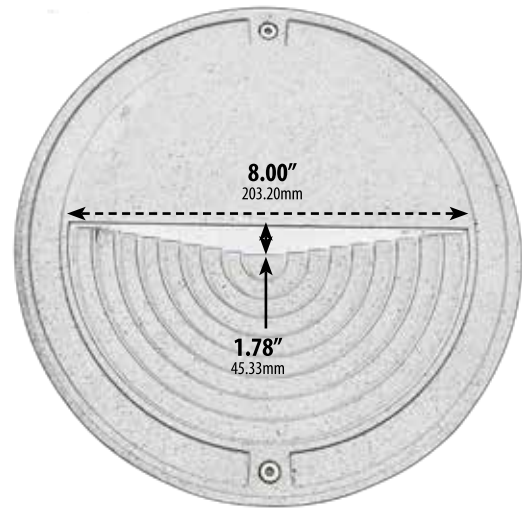
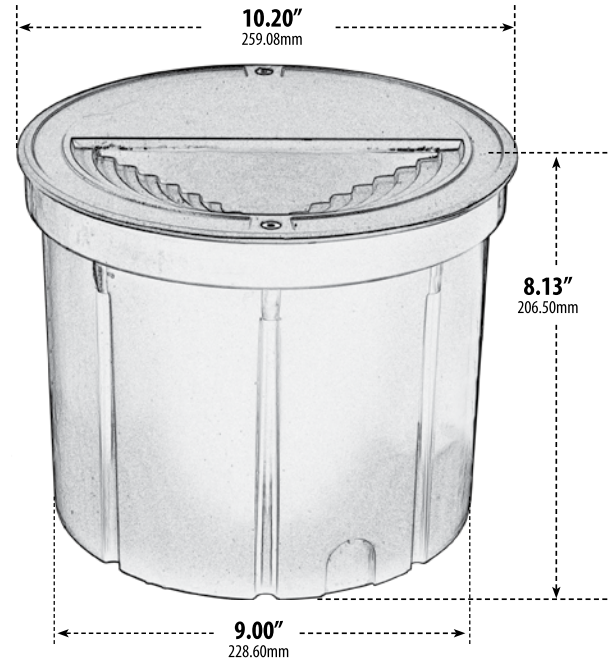

- ▶ **Material:** Powder Coated Cast Aluminum
- ▶ **Lens:** Frosted, Heat Resistant, Tempered Glass

MODEL NUMBER	LAMP TYPE	ILLUMINANT TYPE	WATTS (W)	VOLTS (V)	LAMP(S) INCLUDED?
DSL1120-LED12	2-PIN LED	LED	12	120-277	YES

- ▶ **Available Finish:** Black, Verde Green
- ▶ **Recessed Mount**
- ▶ **ETL Approval Pending**

Overall Dimensions:
10.88"H x 10.88"W x 5.20"D

Weight: 7.13lbs
Box Dimensions: 0.00"H x 0.00"W x 0.00"D
Lamp Included

DABMAR
LIGHTING

DABMAR LIGHTING INCORPORATED

2140 Eastman Ave . Oxnard, CA 93030 . 805.604.9090 . f: 805.604.9050 . www.dabmar.com