

DW1200-GRL SERIES

IN-GROUND WELL LIGHT w/GRILL

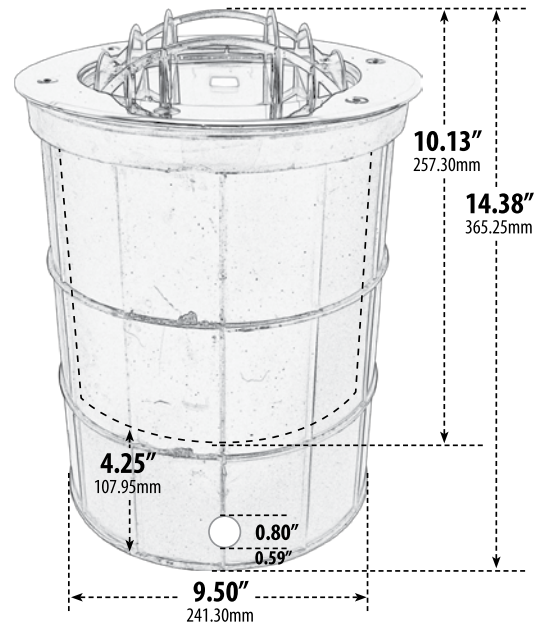
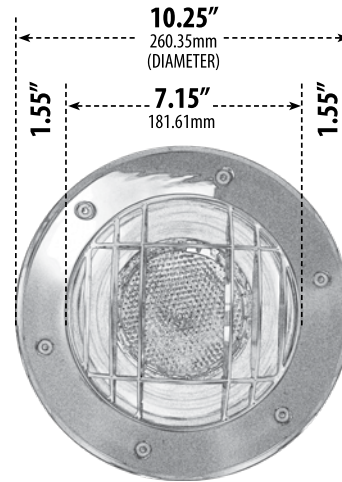

- ▶ **Material:** Stainless Steel w/PVC Sleeve
- ▶ **Lens:** Clear, Heat Resistant, Tempered Glass

MODEL NUMBER	LAMP TYPE	ILLUMINANT TYPE	WATTS (W)	VOLTS (V)	LAMP(S) INCLUDED?
DW1200-GRL	PAR38	INCANDESCENT	150	120	NO
DW1200-GRL-LED18-F	PAR38 LED	LED FLOOD	18	120-277	YES
DW1200-GRL-LED18-S	PAR38 LED	LED SPOT	18	120-277	YES
DW1235-GRL	HID	HPS	35	120	YES
DW1250-GRL	HID	HPS	50	120	YES
DW1270-GRL	HID	HPS	70	120	YES
DW1300-GRL	HID	HPS	100	120	YES
DW1351-GRL	HID	MH	50	120	YES
DW1352-GRL	HID	MH	70	120	YES

- ▶ **Installation Type:** Rated for In-Ground Soil and Concrete Applications
- ▶ **Available Finish:** Stainless Steel
- ▶ **ETL Approved**

LED Available in Warm or Cool White

Overall Dimensions:
14.38"H x 10.25"W x 10.25"D

Weight: SEE LIST
Box Dimensions:
12.50"H x 10.50"W x 10.50"D

Lamp Included

- DW1200-GRL - 8.6 lbs
- DW1214-GRL - 13 lbs
- DW1235-GRL - 17 lbs
- DW1250-GRL - 17 lbs
- DW1270-GRL - 17 lbs
- DW1300-GRL - 17 lbs
- DW1351-GRL - 17 lbs
- DW1352-GRL - 17 lbs

DABMAR
LIGHTING

DABMAR LIGHTING INCORPORATED

320 Graves Ave . Oxnard, CA 93030 . 805.604.9090 . f: 805.604.9050 . www.dabmar.com
4693 19th Street Ct E . Bradenton, FL 34203