

# FG320

## IN-GROUND WELL LIGHT

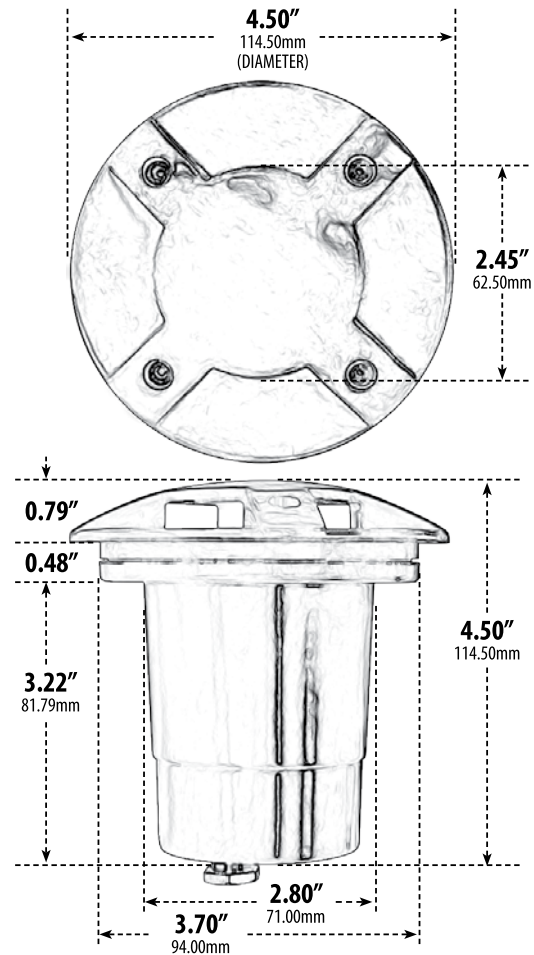

- ▶ **Material:** Fiberglass
- ▶ **Lens:** Clear, Heat Resistant, Tempered Glass
- ▶ **Lamp:** MR16 Bi-Pin Base (20W Maximum) Available in 27K or 65K

MODEL NUMBER	LAMP TYPE	ILLUMINANT TYPE	WATTS (W)	VOLTS (V)	LAMP(S) INCLUDED?
FG320	MR16	HALOGEN	20	12	YES
FG320-LED3	MR16-LED	LED	3	12	YES
FG320-LED5	MR16-LED	LED	5	12	YES
FG320-LED7	MR16-LED	LED	7	12	YES
FG320-LED4-RGBW	MR16-LED	LED	4	12	YES

Pre-wired with UL Listed Direct Burial Wire/Cable

- ▶ **Installation Type:** Rated for In-Ground Soil and Concrete Applications
- ▶ **Available Finish:** Bronze
- ▶ **RGBW Lamp Requires/Remote:** P-RMT-DL-MR16-LED-4W-MC (sold separately)
- ▶ **ETL Approved**

### \*Corrosion Resistant-Ocean Front Placement

Overall Dimensions: 4.50"H x 4.50"W x 4.50"D

Maximum Height: 4.50"

Width: 4.50"

Maximum Depth: 4.50"

Weight: 0.80 lbs

Approximate Wire Length: 16"

Box Dimensions: 5.25"H x 4.75"W x 4.75"D

**DABMAR**  
LIGHTING

DABMAR LIGHTING INCORPORATED

320 Graves Ave . Oxnard, CA 93030 . 805.604.9090 . f: 805.604.9050 . www.dabmar.com