

# GM125-SS

## WALL FIXTURE

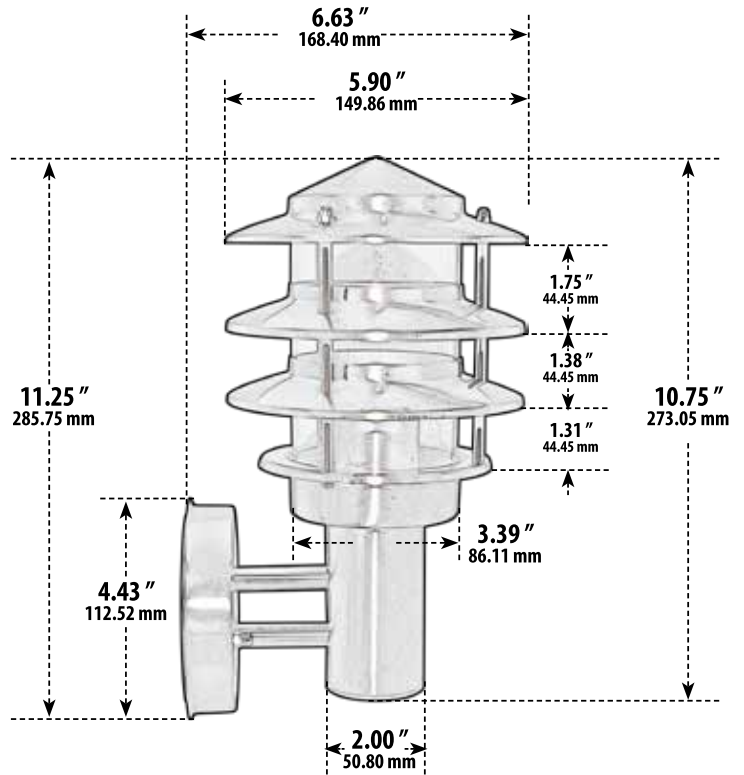

Overall Dimensions:  
11.25"H x 5.90"W x 6.63"D

Weight: 2.4 lbs  
Approximate Wire Length: N/A  
Box Dimensions:  
11.00"H x 7.25"W x 6.25"D

- ▶ **Material:** Stainless Steel
- ▶ **Lens:** Clear, Heat Resistant, Tempered Glass
- ▶ **Available Finish:** Stainless Steel
- ▶ **ETL Approval Pending**

MODEL NUMBER	LAMP TYPE	ILLUMINANT TYPE	WATTS (W)	VOLTS (V)	LAMP(S) INCLUDED?
GM125-SS	A-Type	Incandescent	60	120	NO
GM125-LED6-SS	A-19 LED	Filament LED	6	120	YES
GM125-LED9-SS	GU24-LED	A19-LED	9	120	YES

LED Available in Warm or Cool White

**DABMAR**  
LIGHTING

DABMAR LIGHTING INCORPORATED

320 Graves Ave . Oxnard, CA 93030 . 805.604.9090 . f: 805.604.9050 . www.dabmar.com