

LV-LED704-SS316

BRICK, STEP AND WALL LIGHT

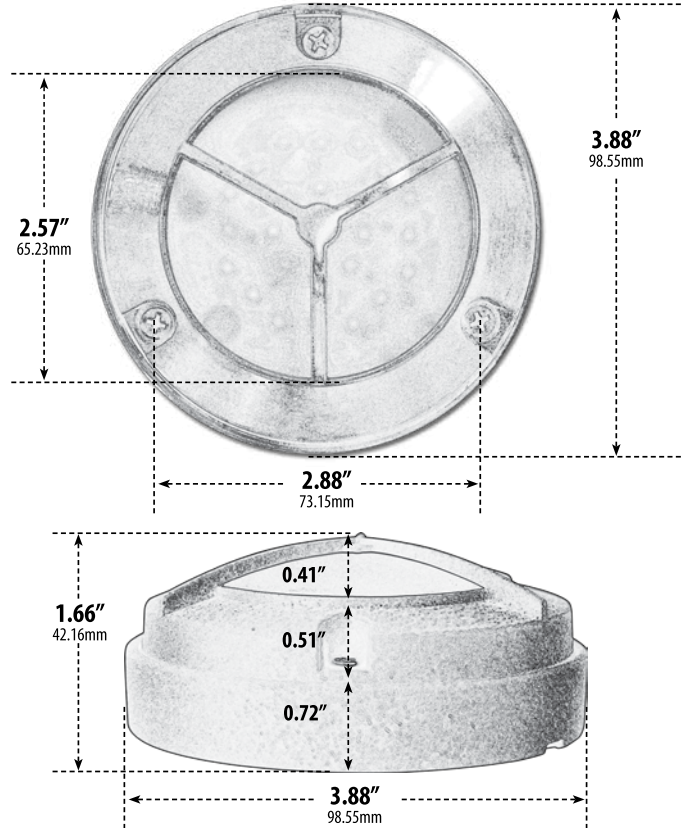

- ▶ **Material:** Marine Grade 316 Stainless Steel
- ▶ **Lens:** Frosted, Heat Resistant, Tempered Glass
- ▶ **Lamp:** Integral LED Circuit Board

MODEL NUMBER	LAMP TYPE	ILLUMINANT TYPE	WATTS (W)	VOLTS (V)	LAMP(S) INCLUDED?
LV-LED704-SS316	LED BOARD	24 LEDs	1.44	12	YES

- ▶ **Available Finish:** Stainless Steel
- ▶ **Surface Mount**
- ▶ **Connector Available:** P-CN01 (sold separately)
- ▶ **ETL Approval Pending**

Overall Dimensions:
3.88"H x 3.88"W x 1.67"D

Maximum Height: 3.88"
Width: 3.88"
Maximum Depth: 1.67"

Weight: 0.60 lbs
Approximate Wire Length: 1.00"
Box Dimensions: 4.25"W x 4.25"H x 2.25"D

DABMAR
LIGHTING

DABMAR LIGHTING INCORPORATED

320 Graves Ave . Oxnard, CA 93030 . 805.604.9090 . f: 805.604.9050 . www.dabmar.com