

LV305-SLV

ADJUSTABLE IN-GROUND WELL LIGHT w/GRILL

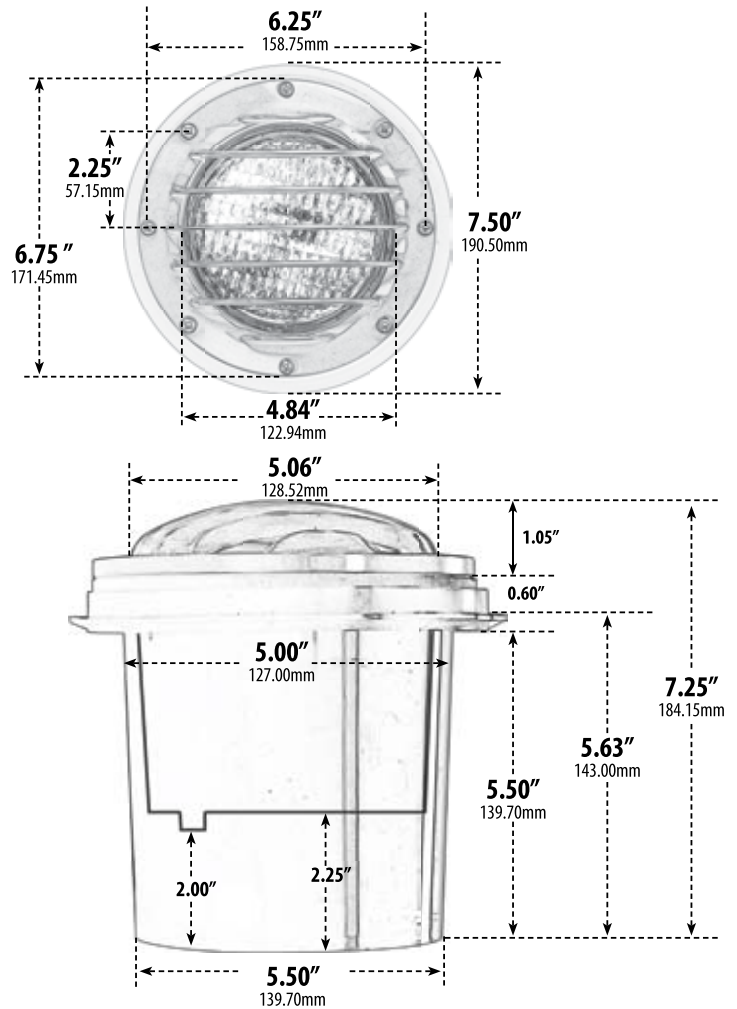

- ▶ **Material:** Powder Coated Cast Aluminum with PVC Sleeve
- ▶ **Lens:** Clear, Heat Resistant, Tempered Glass
- ▶ **Lamp:** PAR36 (50W Maximum)

MODEL NUMBER	LAMP TYPE	ILLUMINANT TYPE	WATTS (W)	VOLTS (V)	LAMP(S) INCLUDED?
LV305-SLV**	PAR36	HALOGEN	35	12	YES
LV-LED305-SLV	PAR36-LED	60 LEDs	4	12	YES

Pre-wired with UL Listed Direct Burial Wire/Cable

- ▶ **Available Finish:** Black, Bronze, Green, Verde Green, Electroplated Stainless Steel
- ▶ **ETL Approved**

** Add -AR111-LED to number for 14W LED

Overall Dimensions:
7.25"H x 7.50"W x 7.50"D

Weight: 3.0 lbs
Approximate Wire Length: 15"

Box Dimensions:
7.00"H x 8.00"W x 8.00"D

DABMAR
LIGHTING

DABMAR LIGHTING INCORPORATED

2140 Eastman Ave . Oxnard, CA 93030 . 805.604.9090 . f: 805.604.9050 . www.dabmar.com